

AFLQWT



ULTRASONIC FLOW METER
AFLOWT UF

(with cut-in converters)
VERSION UF-5xx d

OPERATION MANUAL
PART I



ISO 9001:2015

* * *

**Manufacturer quality management system is certified to
ISO 9001:2015**



* * *

URL: <http://www.aflowt.com>

TABLE OF CONTENTS

	Page
INTRODUCTION	4
DEVICE VERSIONS	5
1. DESCRIPTION AND OPERATION	6
1.1. Application	6
1.2. Specifications.....	7
1.3. Metrological specifications	9
1.4. Contents of the delivery package.....	10
1.5. Device structure and operation	11
1.5.1. Operation principle.....	11
1.5.2. Device structure.....	13
1.5.3. Access levels	14
1.5.4. External connections.....	16
1.5.5. Logging.....	18
1.6. Flowmeter's components	19
1.6.1. Secondary Measuring Converter.....	19
1.6.2. Electro-acoustic converters.....	21
1.6.3. Pipeline sections.....	21
1.7. Marking and sealing.....	22
2. OPERATION	23
2.1. Operating restrictions.....	23
2.2. Preparing for operation	23
3. MAINTENANCE	25
4. PACKING, STORAGE AND TRANSPORTATION	26
APPENDIX A. View of components	27
APPENDIX B. Wiring diagrams	34

This document covers "AFLOWT UF" ultrasonic flowmeters of UF-510 d, -520 d, -522 d, -530 d, -540 d, -542 d, -544 d versions with cut-in converters and contains the information about their design and operation.

Part I is devoted to technical description and maintenance procedures. Part II describes flowmeter's operation.

Due to continuous improvement of product policy, actual flowmeter's specifications may differ from the data specified in this manual. However, this will not affect the metrological characteristics and functionality.

LIST OF ABBREVIATIONS

CB	- Communication block
CS	- Secondary measuring converter
DN	- Nominal diameter
LCD	- Liquid crystal display
SPS	- Secondary power source
PS	- Pipeline section
ER	- Error
CP	- Primary converter
PEA	- Electro-acoustic converter
USS	- Ultrasonic signal.

NOTE. Words in the text marked in bold, for example, **Settings** correspond to the items displayed on the flowmeter's screen.

DEVICE VERSIONS

Depending on application, the flowmeter comes in various design versions.

Design versions intended for various applications differ in number of measuring channels and type of sounding method. The design versions available are listed in Table 1.

Table 1

Design version	Number of channels	Sounding method	Qty of CPs
UF-510 d	1	single-beam	1
UF-520 d	2	single-beam	2
UF-522 d		two-beam	1
UF-530 d	3	single-beam	3
UF-540 d	4	single-beam	4
UF-542 d		two-beam	2
UF-544 d		four-beam	1

1. DESCRIPTION AND OPERATION

1.1. Application

1.1.1. "AFLOWT UF" ultrasonic flowmeter of UF-5xx d versions is designed to measure average volumetric flow rate and volume of bidirectional flows of various liquids (hot, cold and waste waters, acids, caustics etc.) in one or several pressure pipelines under various operating conditions.

The flowmeter is suitable for a wide range of applications in power industry, municipal engineering as well as in oil, gas, food and other industries. The flowmeters may be used as part of heat meters, metering systems, automatic process control systems etc.

"AFLOWT UF-5xx d" is suitable for measuring flow rate and volume of liquid food products including alcohol-free drinks (juices, syrups and the like), alcohol drinks, dairy products (milk, yoghurt, kefir, sour cream etc.), mayonnaise, ketchup, solutions of food acids and alkalis etc.

1.1.2. "AFLOWT UF-5xx d" ultrasonic flowmeter performs the following functions:

- Measuring average volumetric flow rate in either forward or reverse flow directions through 1-4 measuring channels (pipelines)
- Totalizing volume of forward and reverse flow independently and calculating their algebraic sum with regard to flow direction for each measuring channel
- Determining the current value of flow velocity and flow direction for each channel
- Batching preset liquid volume or batching in the start-stop mode along with determining the amount of batched liquid, batching time and flow rate
- Outputting measurement results to the analog (current), pulse or logical output
- Logging measurement data and configuration settings in the internal nonvolatile memory
- Displaying measurement, diagnostic, configuration and history (logged) data on the built-in indicator, data is transferred via RS-232 or RS-485 interface using dedicated cable, phone cable, Ethernet interface, radio channel or telecommunications channel
- Configuring flowmeter's settings according to on-site and process requirements
- Monitoring and indicating alarm conditions (error situations) and faults; recording error and fault types and intervals into the dedicated logs
- Providing protection of logged data and configuration settings from unauthorized access.

1.2. Specifications

1.2.1. General Specifications are listed in Table 2.

Table 2

Parameter	Value	Notes
1. Number of measuring channels	From 1 to 4	Optional
2. Nominal diameter of the pipeline, DN	From 10 to 5000	
3. Temperature of the medium, °C	From - 30 to +160	See note 1
4. Maximal pressure in the pipeline, MPa	2.5	
5. Power supply voltage	DC 24 V	See section 1.2.6
6. Power consumption, W	no more than 12	
7. Mean time to failure, h	75 000	
8. Mean life time, years	12	

NOTES.

1. Working temperature range depends on the design version of PEAs.

2. In case of ordering cut-in PEAs in standard design version, you may opt for pipeline sections with cut-in PEAs designed for up to 25 MPa pressure.

1.2.2. The flowmeter measures average volumetric flow rate up to 20 m/s flow velocity.

Volume is measured at a flow velocity value of no more than 10.6 m/s. This value can be increased up to 20 m/s.

Flowmeter's sensitivity to flow velocity is no less than 0.01 m/s.

1.2.3. The flowmeter provides the number of digits for displaying measuring results specified in Appendix C (Part II) of this manual.

1.2.4. The flowmeter provides that the results of measurements can be outputted to:

- Universal outputs – from 1 to 9 (optional)
- Analog output – 2 (optional)
- RS-232 (RS-485) interface – 1;
- Ethernet interface – 1 (optional).

1.2.5. The flowmeter provides storage of measurement results in the following logs:

- Hourly log – 1440 records (hourly records) – 60 days
- Daily log – 60 records (daily records)
- Monthly log – 48 records (monthly records)
- Interval log – up to 14400 records
- Batch log – up to 512 records per a channel
- User log – up to 1000 records
- Measuring channels error log – up to 512 records per a channel
- Failure log – up to 60 records
- Mode log – up to 512 records.

When powered off, the flowmeter stores measurement results and configuration settings for no less than 1 year.

1.2.6. The flowmeter is powered from a stabilized 22 ... 29 V DC voltage source with pulse level of no more than $\pm 1.0\%$. The flowmeter can be powered from mains AC (154-264) V (50 \pm 2) Hz via Secondary Power Source.

1.2.7. Environmental restrictions:

a) Ambient temperature

- Secondary converter (CS): ambient temperature from 0 to + 50 °C
- Electro-acoustic converters (PEAs) with plastic protection: liquid temperature from - 30 to + 120 °C
- PEAs with titanium protection: liquid temperature from - 30 to + 160 °C
- Communication block (CB): ambient temperature from - 50 to + 85 °C.

b) Relative humidity

- CS: up to 80 % under + 35 °C, without moisture condensation
- PEAs, CB: up to 100 % under maximum + 40 °C, with moisture condensation.

c) Atmospheric pressure from 66.0 to 106.7 kPa;

Protection provided by the enclosure:

- CS, CB: IP54
- PEA-202, -204, -302, -502, -504: IP68 code; other models: IP67.

1.2.8. View, overall dimensions and weight are given in Appendix A.

1.3. Metrological specifications

- 1.3.1. Limits of permissible relative error for measurement, indication, logging, storage and transferring of average volumetric flow rate and volume measurement results for any flow direction for flowmeters with primary converters¹ (CPs) do not fall outside the following ranges (when type installation² and operation conditions comply with those specified in the present manual):

$$\delta = \pm \left(0,95 + \frac{0,1}{v} \right) \quad \text{– using single-beam sounding method with a liquid viscosity of } \leq 4 \text{ cSt;}$$

$$\delta = \pm \left(1,2 + \frac{0,2}{v} \right) \quad \text{– using single-beam sounding method with a liquid viscosity of } > 4 \text{ cSt;}$$

$$\delta = \pm \left(0,45 + \frac{0,1}{v} \right) \quad \text{– using two-beam sounding method;}$$

$$\delta = \pm \left(0,25 + \frac{0,1}{v} \right) \quad \text{– using four -beam sounding method.}$$

Where δ – limits of permissible relative error, %;

v – flow velocity, m/s.

NOTES

1. “Primary converter” means a pipeline section with PEAs installed on it.
 2. “Type installation” means installation carried out in compliance with the requirements specified in the "ULTRASONIC FLOW METER AFLOWT UF. Version UF-5xx d. Installation manual" document, see Table A.1, Appendix A.
- 1.3.2. The limits of permissible relative measurement error for measuring time of operation in various modes do not exceed ± 0.1 %.

1.4. Contents of the delivery package

Items of the delivery package are specified in Table 3.

Table 3

Item	Qty	Notes
1. Secondary measuring converter (CS)	1	Note1
2. Electro-acoustic converter (PEA)	2 – 8	Note 2
3. Pipeline section (PS)	1 – 4	Note 2
4. Secondary power source 220VAC/=24VDC	1	Optional
5. Installation kit	1	Note 3
6. Communication Block (CB)	1 – 4	Optional
7. Operating documentation:	1	
- Passport		
- Operation manual, part I and II		
- Installation manual		

NOTES.

1. The number of measuring channels and communication (service) modules is specified in the order sheet.
2. The quantity and type are specified in the order sheet.
3. In standard supply configuration CS-PEA cable length is 10 m (2×10 m per a channel).

Operating documentation for this product and other products are available on: www.aflowt.com.

1.5. Device structure and operation

1.5.1. Operation principle

1.5.1.1. The flowmeter is a transit time ultrasonic flow meter. Its operation principle is based on measuring the time difference between the time it takes for an ultrasonic signal (USS) to travel through the liquid with the direction of flow and against it.

1.5.1.2. The CS generates electric sounding pulses which alternately come to PEA1 and PEA2 (Fig.1).

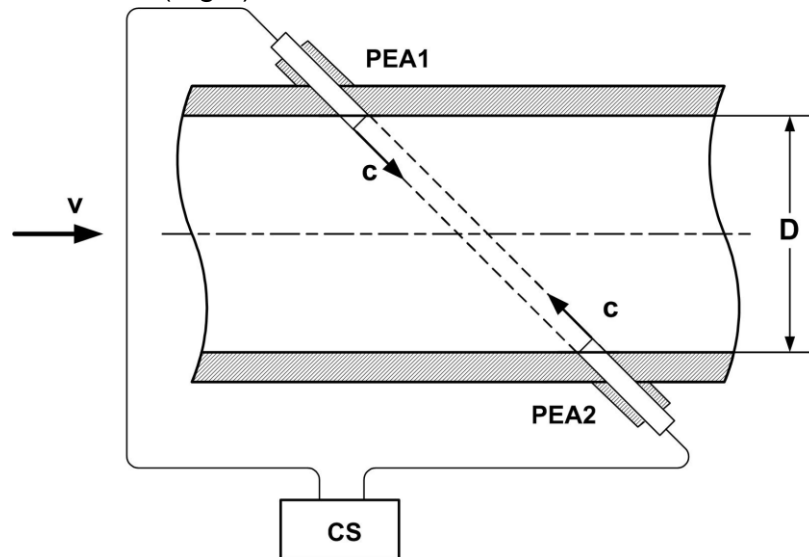

Fig.1. Diagram showing USS propagation

USS generated by one PEA (electro-acoustic transducer) is projected through the liquid flowing in the pipe and is received by the other PEA. Because of liquid flow, a sound wave is shifted, which in turn leads to the difference in upstream and downstream times of USS travel. It takes less time for an ultrasonic signal to travel in the flow direction (from PEA1 to PEA2) than that in the opposite direction (from PEA2 to PEA1). The difference in upstream and downstream time of USS travel through an acoustic path dT is proportional to flow velocity of fluid v and, correspondingly, to volumetric flow rate Q .

The digital method of processing the received PEA signals ensures stable operation under noise conditions, and also simplifies the adjustment of the flow meter during commissioning

1.5.1.3. In a two-beam flowmeter designed on two-channel basis, one PS (pipe-line section) bears two couples of PEAs. In a four-beam flowmeter designed on four-channel basis, one PS bears four couples of PEAs. Flow rate is measured independently for each beam.

1.5.1.4. The flow rate value is calculated only if the following condition is fulfilled:

$$Q_{\min} \leq Q,$$

Where Q_{\min} – minimal value of the flow rate, m^3/h ;

Q – current value of the flow rate, m^3/h .

The recommended value of lower flow cutoff corresponds to flow velocity of 0.035 m/s.

If $Q < Q_{\min}$ condition is fulfilled, the measured flow rate values are displayed as zero, value totalizing and pulse transmission to the universal output are cancelled, and the value of current at the output becomes equal to the lower range value.

If $Q > Q_{\max}$ (where Q_{\max} corresponds to the flow velocity value of 10.6 m/s), the flowmeter measures and displays flow rate values, however, volume totalizing and logging, as well as pulse transmission to the universal output in the pulse mode, are cancelled. The value of current at the output becomes equal to the upper range value.

1.5.1.5. Cut-in PEAs are mounted into the holes cut in the pipeline section (PS). The PEAs are installed on the pipeline according to the diagrams shown in Fig.2.

- Z-configuration – PEAs are located on opposite sides of the PS in a plane going through the PS centerline ("diametral" installation – only for single-beam sounding method), or PEAs are arranged in parallel with the PS centerline ("chord" installation – for two-beam or four-beam sounding method). In this case, an ultrasonic beam goes from one PEA to another without reflection from the internal of the pipeline section
- For pipeline sections of U-type (U-elbow) – cut-in PEAs are placed on the ends of the PS straight section, and USS travels along the liquid flow.

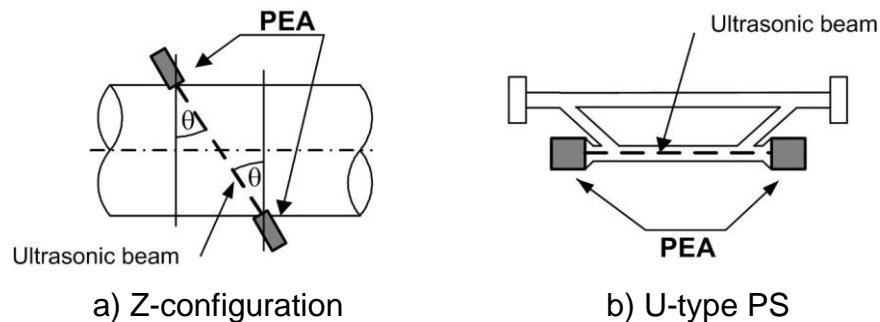
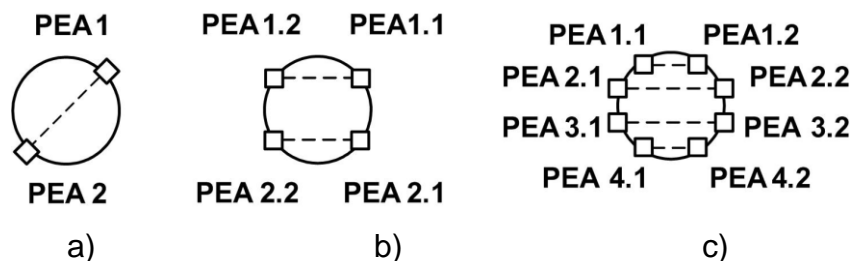

Fig.2. PEA installation diagrams

For cut-in PEAs installed in the straight PS, a longitudinal angle θ (angle between the axis of the cut-in PEA and the plane normal to the pipeline centerline) can range from 20° to 70° . The recommended value is $\sim 45^\circ$.

1.5.1.6. The flowmeter allows for single-, two- or four-beam sounding of liquid flow (Fig.3).



- a) single-beam "diametral" sounding;
- b) two-beam "chord" sounding;
- c) four-beam "chord" sounding.

Fig.3. Arrangement of PEA pairs in pipeline cross-section according to sounding method

Table 4. PEA installation options

Sounding method	1-beam		2-beam and 4-beam
PEA installation configuration	U-elbow type PS	Z-configuration	Z-configuration
Arrangement of PEA pairs	Along flow axis	On the diameter	On the chord
DN of pipeline section,	<50	≥50	≥150

1.5.2. Device structure

The flowmeter's block diagram is shown in Fig.4.

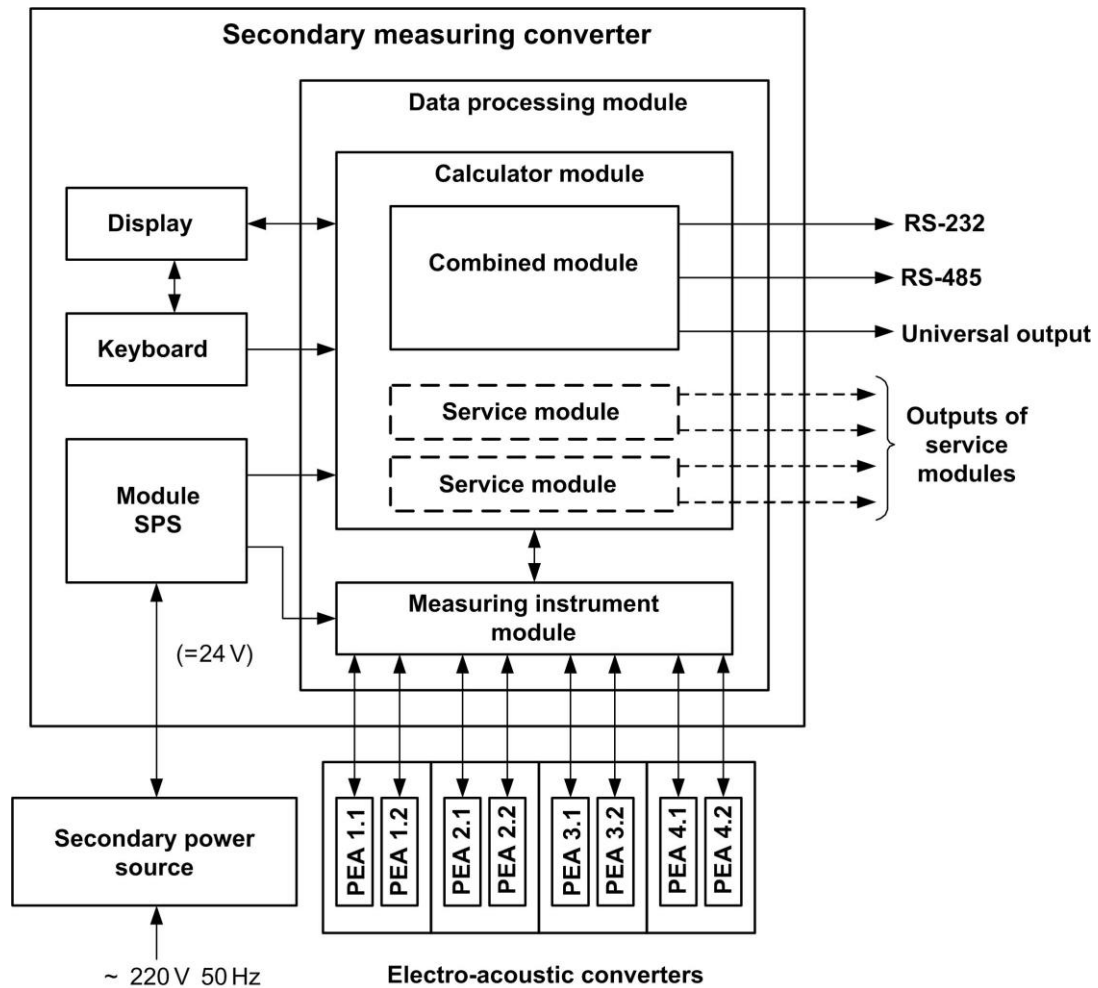

SPS – Secondary Power Source.

Fig.4. Block diagram for 4-channel flowmeter

"AFLOWT UF" ultrasonic flowmeter includes one or several primary converters and a secondary measuring converter.

The primary converter is a specially designed measuring tube with one, two or four pairs of PEAs installed on it.

Number of primary converters used with the flowmeter and PEA pairs installed on the PS depends on the flowmeter's design version.

The secondary measuring converter consists of measuring and calculation modules. The measuring module is responsible for electroacoustic sounding control and measurement signal processing. The cal-

ulation module performs secondary processing and storage of measurement results. Data exchange between the measuring and calculation boards is performed via internal RS-485 interface.

To provide data exchange with external devices, the calculation board is equipped with the combined module consisting of universal, RS-232 and RS-485 output circuits.

You may opt for installation of up to 2 additional communication modules:

- One module of universal outputs (four outputs per a module)
- Module of analog output
- Ethernet interface module.

Flowmeter's operation is controlled from the keyboard. The graphic Liquid Crystal Display (LCD) makes visible measurement, diagnostic, configuration, and history (logged) data. LCD displays data in four lines (20 characters per line). On-screen data update period is 1 s.

1.5.3. Access levels

1.5.3.1. The flowmeter has three levels of access to setting and calibration parameters:

- SETUP – setup and verification
- SERVICE – start-up procedures
- OPERATION – user mode.

The operating modes differ by level at which the user can access certain data (displayed and/or transferred via RS-232 or RS-485 interfaces) and modify flowmeter's configuration settings.

Maximum rights are granted in the SETUP mode. The mode allows the user to view all of the parameters and to modify all of the configuration settings. Minimum rights are given in the OPERATION mode.

Flowmeter's operation is controlled from the keyboard via the menu designed on the model of nested menus and windows. Operation procedures, indication principles, menu structure, and tables of displayed parameters are specified in Part II of the present manual.

The flowmeter can be externally controlled via RS-232 and RS-485 interfaces.

1.5.3.2. Flowmeter's operating modes are set by placing (removing) jumpers on J3 and J4 terminals, which are located on the combined module ("RS-232 / RS-485 / Universal output 0").

Combinations of jumpers with regard to operating modes are specified in Table 5, where "+" means that the terminal contacts are closed by a jumper and "-" means that the terminal contacts are opened.

Table 5

Mode	Terminal		Mode description
	J3	J4	
OPERATION	-	-	Work
SERVICE	-	+	Start-up procedures
SETUP	+	-	Adjustment

1.5.3.3. OPERATION mode – flowmeter's on-site operation.

In the OPERATION mode, the user can view the following parameters:

- a) measurement values: average volumetric flow rate, flow volume totalized for forward and reverse flow and their algebraic sum, flow velocity;
- b) measurement data and status logs (excluding the "Mode" and "User" logs);
- c) configuration settings: automatic winter/summer time clock setting, types of service modules installed, and specifications of outputs;
- d) operation settings:
 - Reading of built-in real time clock
 - RS-232 and RS-485 settings
 - Start time and duration of error situations (ER)
 - Error messages related to measuring channels and outputs.

In the OPERATION mode, the user can specify batching value and enable batching procedure as well as specify RS-232 and RS-485 settings: flowmeter's network address, data transfer rate, delay duration, transfer gaps etc.

1.5.3.4. SERVICE mode – start-up procedure.

In the SERVICE mode, in addition to the above, available in the OPERATION mode, the operator can do the following:

- a) view the "Mode" and "User" logs;
- b) view and modify:
 - Settings of pipeline sections
 - Measuring results processing settings
 - Service settings
 - Flowrate (volume) measurement units [m^3/h ; m^3/s ; l/min (m^3 ; l)]
 - Type and settings of communication modules
 - Interval log settings
 - Reading of built-in real time clock
 - Automatic winter/summer time clock setting.
- c) perform on-site verification;
- d) set totalizer to zero;
- e) perform flowmeter's initialization;
- f) clear status logs (excluding the User log) and data logs; the "Mode" log cannot be cleared in none of the operation modes.

1.5.3.5. SETUP mode allows to view and modify all of the settings.

In the SETUP mode, in addition to the above, available in the OPERATION and SERVICE modes, the operator can do the following:

- Verification the flowmeter
- Clear the User log
- Enter flowmeter's serial number into the memory.

1.5.4. External connections

1.5.4.1. Serial interfaces

Serial interfaces are used to control the flowmeter, read measurement results, data logs, configuration settings, and diagnostic data as well as to modify configuration settings. The RS-232 and RS-485 interfaces support ModBus (RTU ModBus and ASCII ModBus).

The RS-232 interface may be used for connection to a PC via:

- Cable (maximal cable length is 15 m)
- Phone line (telephone modem)
- Wireless channel (wireless modem)
- 900/1800 MHz GSM line via mobile communications adapter.

Communication distance via phone, wireless or mobile communications channel is determined by characteristics of the channel.

RS-485 interface supports cable communications among a group of several end users, one of which can be a PC, at a distance of up to 1200 m.

Connection of Mobile Communications adapter either to a group or to a single device allows for data transfer via wireless communications channel including the Internet.

The data transfer rate via RS-232 and RS-485 interfaces (from 1200 to 19200 baud) as well as communication properties are set from a PC.

CAUTION! You must not use RS-232 and RS-485 interfaces simultaneously.

Ethernet interface is used for connecting the devices via local network or for data exchange among the LAN devices and a remote PC via the Internet. Data exchange is performed via a LAN gateway having its own (global) IP address. Transferred data is packaged using Ethernet / IP / UDP / TFTP / ModBus stack of protocols. ARP (Ethernet / ARP) protocol is also supported. It is used to define MAC-address of the node by IP address on request. Connection to Ethernet network is made as per Fig.A.4, Appendix A.

1.5.4.2. Universal outputs

Depending on the number of service modules installed (see section 1.6.1.3), the flowmeter can have from 1 to 9 galvanically isolated universal outputs.

Functions, working modes, specifications of output signals and disconnection of the outputs are specified programmatically. Options available are specified in Table B.6 represented in Part II of this manual.

Diagrams of output stages, description of operation and signal levels are given in Fig.B.3 (Appendix B).

In the frequency mode, measurement results are outputted in the form of square pulse sequence with period-to-pulse duration ratio of 2 and pulse repetition rate proportional to the current flowrate value. The frequency output can be scaled by specifying maximal frequency **F_{max}**, scale factor **K_C**, as well as lower **Q_{lt}** and upper **Q_{ut}** threshold flowrate

values related to output frequencies of 0 Hz and **Fmax**. Maximum value of **Fmax** is 3000 Hz.

In the pulse mode, a burst of pulses is generated on the output within a second, in which the number of pulses (considering pulse weight **Kp**) corresponds to the flow volume measured over a previous second. Maximum pulse repetition rate in the burst (square pulse sequence with period-to-pulse duration ratio of 2) is 500 Hz.

To provide correct work of the universal outputs, the scale ratio **KC** (pulses/m³, pulses/l) in the frequency mode and pulse weight **Kp** (m³/pulse, l/pulse) in the pulse mode are calculated automatically.

KC calculation is made on the basis of user-specified **Qut** and **Qlt** values and **Fmax** value. **Kp** is derived from **Qut** value and duration of output pulses τ lying within the range of 1 to 500 ms.

In the logical mode, one signal level corresponds to “event” (or its state) and the other level corresponds to “no event” (or another state).

Programmatically this means: **Active level**, i.e. **High** or **Low** signal level, is set when the event is present.

In the batching mode, output signal parameters depend on the operation mode (pulse or logical) of the universal output.

If the universal output operates in the pulse mode and the value specified in **Param.** field is **<pul. batcher>**, one pulse of programmed duration is generated on the universal output on completion of batching.

If the universal output works in the logical mode, output signal level is changed at the moment of start or stop of batching.

1.5.4.3. Analog output

Current signal is provided by the corresponding service module. Function and operational parameters of the analog output module are specified programmatically. Options available are specified in Table B.6 represented in Part II of this Manual.

Galvanically isolated analog output realized on the base of the service module works in one of three ranges: 0-5 mA, 0-20 mA or 4-20 mA.

Nominal static characteristic of the analog output is calculated as follows:

$$Q_v = Q_{lt} + (Q_{ut} - Q_{lt}) \frac{I_{out} - I_{min}}{I_{max} - I_{out}}$$

Where Q_v – measured flowrate value (m³/h; m³/s; l/min);

Q_{lt} – specified value of lower threshold for the analog output corresponding to I_{min} , m³/h; m³/s; l/min;

Q_{ut} – specified value of upper threshold for the analog output corresponding to I_{min} , m³/h; m³/s; l/min;

I_{out} – value of output current signal corresponding to the measured flow rate, mA;

I_{min} – minimal operating range for the analog output (0 or 4), mA;

I_{max} – maximal operating range for the analog output (5 or 20), mA.

The analog output can be connected to an external load of up to 1 kOhm in (0-20) mA or (4-20) mA operating ranges or of up to 2.5 kOhm in (0-5) mA operating range.

Permissible length of a signal cable connected to the analog output depends on the impedance of the corresponding signal circuit and impedance of a connected input. The condition is that the sum of impedances shall not exceed the specified external load resistance.

1.5.5. Logging

1.5.5.1. Measurement results are recorded into device's internal logs: hourly, daily, monthly, interval, and batcher logs.

Hourly, daily, and monthly logs are filled independently for each channel and have the same structure. Log capacity:

- Hourly log – 1440 records (hourly records)
- Daily log – 60 records (daily records)
- Monthly log – 48 records (monthly records)
- Interval log – 14400 records (data recorded during specified intervals).

For the interval log, interval duration can be selected from 5 s to 120 min.

Format of one record is as follows:

- **Tdw** – dead time, s – in the hourly log, hours:min – in the daily and monthly logs; for the interval log, **Tdw** is not recorded
- **V+** – total volume for direct flow over logging interval, m³ (l)
- **V-** – total volume for reverse flow over logging interval, m³ (l)
- **ΣV** – total volume with regard to flow direction over logging interval, m³ (l).

In addition, USS failure per each of 4 beams is represented in the record in text message.

Measurement data are logged along with logging interval indication:

- Date and hour – for hourly logs
- Date – for daily logs
- Month and year – for monthly logs
- Date and stop time of the logging interval – for interval logs.

Search function is built in to enable the user to find the required record in any log.

1.5.5.2. The purpose of the batcher log is to record the parameters based on the results of batching. The log has a capacity of 512 records per a channel. The format of a record is as follows:

- Date and start time of batching
- **Ve** – preset batch value, m³ (l)
- **Vb** – measured batch value, m³ (l)
- **Tb** – batch accumulation time, s
- Date and stop time of batch accumulation
- **Qavg** – average volumetric flow rate during batching, m³/h (l/min).

1.5.5.3. Modifications made on configuration settings are logged in the User log with a capacity of 1000 records. User log format is as follows:

- Modification date and time
- Name of the modified parameter
- Parameter's value prior to modification
- Parameter's value after modification
- Order number of the record.

1.5.5.4. Modifications made on the operation mode are logged in the Mode log with a capacity of 512 records.

Mode log format is as follows:

- Order number of the record
- Name of the active operation mode
- Date and time of activation.

1.5.5.5. Error conditions and faults are recorded into the Measuring Channels error log, Outputs error log (universal and analog outputs) and Failure log. The Error logs can contain up to 512 records, the Failure log has a capacity of 60 records.

Error log format:

- Order number of the record
- Alarm (error) name
- Date and start time of the alarm (error) situation (ER)
- ER duration (hours, minutes, seconds)
- Date and stop time of the alarm (error) situation (ER).

Failure log format is as follows:

- Order number of the record
- Fault name
- Date and time of fault detection.

1.6. Flowmeter's components

1.6.1. Secondary Measuring Converter

1.6.1.1. CS functions

The Secondary Measuring Converter (CS) is a Measurement/Calculation Data Processing Block designed on the modular principle. The CS provides:

- Flow sounding and processing of signals obtained from PEAs
- Calculation of measured values
- Logging and storing of measurement results, calculated parameters, configuration settings etc. in the flowmeter's non-volatile memory
- Transferring of measurement, history (logged), diagnostic, and configuration data to LCD display via RS-232, RS-485 interfaces
- Data transfer to the universal outputs
- Automatic monitoring and indication of alarm conditions and faults
- Protection of logged data and configuration settings from unauthorized access.

1.6.1.2. CS design

View of the CS is shown in Fig.A.1, Appendix A.

The CS consists of three parts (modules): front part – Data Processing Module, center part – SPS (Secondary Power Source) module, and base part - Mount module. The Data Processing Module comprises measurement and calculation boards. LCD graphic display and keyboard are both mounted on the module's front panel.

The SPS CS module includes Secondary Power Source board. Grounding terminal is located on the SPS bottom panel.

The SPS module and Data Processing module are electrically (by the multiple-wire flexible flat cable) and mechanically (by the screws installed from the SPS side) connected and build up the Data Processing Subblock.

The Data Processing Subblock is in turn screwed with the CS Mount module from the front panel side, and together, they build up the Secondary Converter block. The rear panel has fixing holes for the brackets, which are used to mount the Secondary Converter on DIN rail (Fig.A.5).

Bottom panel of the Mount module contains: external RS-232 port and cable through for power cable, PEA signal cables, and external signal cables.

The external RS-232 port located on the Mount module is connected to the 8-pin RS-232 port of the Combined Electronic Module by a flexible flat cable.

Connectors on the measurement and calculation boards, which are used to connect signal cables and set operation modes, are accessed from the rear side of the Data Processing Subblock (Fig.A.2).

1.6.1.3. Communication modules

Depending on the number of measuring channels (PEA pairs), the Measurement board includes the corresponding number of transmitting/receiving communication modules: from 1 to 4.

The Combined output module containing the Universal 0, RS-232, and RS-485 outputs is installed on the Calculation board. The Combined module is equipped with the terminals (used to set operation modes for the flowmeter and output stage of the universal output) and the connectors (used for external cable connections).

The Calculation board bears two expansion slots (connectors) intended for connection of one or two optional external communication (service) modules.

The service modules are equipped with the connectors used to connect signal cables from signal receivers, and, besides the above, the universal output modules bear the terminals for setting operating modes of the output stages. An example of marking the connectors on the Data Processing Subblock is given in Fig.A3, Appendix A.

Table 6 shows possible combinations of the external communication modules and numbering of outputs relative to module (expansion slot) location.

Table 6

Module name	N of the slot	N of the output	Possible combinations of modules						
Communication module of Universal outputs	1	1...4	–	–	–	×	×	×	×
	2	5...8	–	–	–	–	–	–	×
Communication module of Analog output	1	1	×	–	×	–	–	–	–
	2	2	–	–	–	–	×	–	–
Ethernet Communication module	2	2	–	×	×	–	–	×	–
Combined module	–	0	×	×	×	×	×	×	×

1.6.2. Electro-acoustic converters

1.6.2.1. PEAs alternately operate in two modes: transmitter mode, in which the electrical pulse signal coming from the CS is transduced into ultrasonic waves, and receiver mode, in which ultrasonic waves in liquid are transduced into the corresponding electrical signal.

1.6.2.2. PEAs come cut-in type

The cut-in PEAs (Fig.A.6) come in cylindrical case with the transmitting plane in the flat end. The cut-in PEAs are mounted into the holes cut in the pipeline side so that the transmitting (radiating) plane contacts the medium. PEAs are sealed with heat-resistant electrically insulating compound.

To provide PEA-CS communication, the coaxial RF cable of no less than 1.5 m is fixed to the PEA case with the connector soldered to its end.

Another way to provide the connection is to use the Communication block installed on the pipeline section. In this case, instead of the connector, it is necessary to attach leads to the ends of the central conductor and shield.

Length of CS-PEA communications cables is 100 m as a maximum. The length may be increased provided that the received signal meets the requirements.

Depending on application, the flowmeter is equipped with PEAs of different types and design versions.

1.6.3. Pipeline sections

1.6.3.1. As a pipeline section (PS), you can use a pipe run factory-prepared for PEA installation and on-site mounting of the primary converter into the active pipeline. The material of the walls of the PS under the cut-in PEA should allow her to install mounting pipes for PEA on it tightly.

1.6.3.2. The delivery package may include primary converters installed on pipeline sections of the following types:

- PS- \times 12 – straight with two cut-in PEAs installed on the diameter
- PS- \times 32 – U-type (U-elbow) with two cut-in PEAs installed on the ends of straight section
- PS- \times 42 – straight with 4 cut-in PEAs installed on two chords
- PS- \times 82 – straight with 8 cut-in PEAs installed on four chords.

The first position of PS product identification line indicates PS production material:

- PS-0 \times 2 – carbon steel
- PS-1 \times 2 – stainless steel
- PS-2 \times 2 – frost-proof stainless steel.

1.6.3.3. To provide ease of mounting as well as to avoid mechanical damages to PEA cable ends, the pipeline section with cut-in PEAs can be equipped with Communication block (CB). The CB is intended to provide electrical connections between PEA cables and cables connected to the CS.

The CB is rigidly fixed to the PS. The PEA cable is protected against mechanical damages by a copper sleeve. Design of CB cable entry holes provides fixation of the sleeve used for CS cable mechani-

cal protection. An example of positioning the CB on the pipeline section and its view with the cover removed are given in Fig.A.7 and A.8 (Appendix A). PEA-CB wiring diagrams are shown in Fig.B.2 (Appendix B) respectively.

1.7. Marking and sealing

- 1.7.1. Front panel of the CS bears flowmeter's name and designation, manufacturer's logo, and sign of the Type Approval Certificate. Serial number is indicated on the nameplate located on the CS case.
- 1.7.2. Serial numbers of other units are either indicated on the nameplate or stenciled on the corresponding case.
- 1.7.3. After performing verification, the cap covering J3 terminal, used to enable modification of verification settings, is sealed along with one of the screws fixing the Data Processing Subblock.
- 1.7.4. J4 terminal that enables modification of operation settings is sealed after carrying out the start-up procedure and checking the compliance of the operation settings with the values specified either in the Equipment Certificates for the flowmeter and primary converters or in the Reports on mounting and start-up procedure.

Characteristics of the primary converters (CPs) are determined in the post-manufacture tests and entered in the CP Equipment certificates and in the Report on mounting and start-up procedure. Form of the Report on mounting and start-up procedure is given in the Installation Manual.

2. OPERATION

2.1. Operating restrictions

- 2.1.1. Environmental restrictions with regard to the factors affecting the performance and characteristics of the controlled liquid shall comply with the requirements specified in the operating documentation.
- 2.1.2. The CP can be mounted into the pipeline installed horizontally, vertically, or obliquely.
- 2.1.3. For precision and reliable operation, when choosing PEA mounting location, the following conditions must be met:
 - Liquid pressure in the pipeline and pipeline's operational characteristics must not be of values that may facilitate gas release and/or gas (air) collection
 - Straight pipe runs of appropriate length must be provided upstream and downstream the PEAs. The pipeline installation sections not include devices or components that may disturb flow structure
 - When the flowmeter is operated, the pipeline must be fully filled with liquid.
- 2.1.4. Type and liquid composition (suspensions and their concentration, impurity substances, etc.), operating mode and pipeline conditions must not lead to corrosion and/or sediments affecting the performance and metrological characteristics of the flowmeter.
- 2.1.5. Grounding system is arranged according depending on power supply value and environment conditions.
- 2.1.6. Lightning protection system for the site where the flowmeter is located protects the device against failures caused by lightning strokes.
- 2.1.7. Mounting location and operating conditions requirements specified in this operating documentation are based on the most typical factors affecting flowmeter performance.

The external factors that cannot be foreseen, evaluated or tested by the manufacturer during designing may exist or appear on site.

In this case, it is necessary to eliminate these factors or place the flowmeter in other location.

2.2. Preparing for operation

- 2.2.1. Safety instructions
 - 2.2.1.1. The flowmeter should only be used by the technical staff familiar with all operating documentation for the product.
 - 2.2.1.2. When working with the flowmeter, the dangerous factors are as follows:
 - AC voltage (RMS value up to 264 V, frequency 50 Hz)
 - Pipeline pressure (up to 2.5 MPa)
 - Liquid temperature (up to 160 °C)
 - Other site-specific factors.
 - 2.2.1.3. The CS must not be operated without proper grounding.

2.2.1.4. On detecting external defects on the device or damages to mains cabling, you must remove power from the device and contact the authorised technician for the information about the device's operability.

2.2.1.5. In the course of mounting, start-up or repair works you must not:

- Make connections to the flowmeter, switch over modes and replace electronic components, when the flowmeter is powered up
- Use defective electronic devices and electric tools or use them without proper grounding (neutral earthing).

2.2.2. On-site mounting and adjustment of the flowmeter shall be performed according to the Installation Manual.

The works should be performed by authorized dealers or by the manufacturer.

2.2.3. When putting the flowmeter into operation, check the following:

- The flowmeter and related equipment are connected in accordance with the selected wiring diagram
- Flowmeter's components and connection cables correspond to the characteristics of a certain measuring channel. The correspondence is checked in accordance with the procedure described in the Installation Manual
- Power supply voltage corresponds to the specifications.

Besides the above, it is necessary to make sure that actual operation settings in the flowmeter comply with the values specified in the Equipment Certificates for the flowmeter and primary converters or in the Report on mounting and start-up procedure.

To protect the equipment from unauthorized access, two fixing screws accessed from the CS front panel side can be sealed after putting the flowmeter into operation.

3. MAINTENANCE

3.1. It is recommended to check on regular basis that:

- Performance complies with the specifications
- Operating conditions are met
- Power supply characteristics are within the required ranges
- No external defects are detected
- Electrical and mechanical parts are reliably connected.

Check periods depend on operating conditions but should not exceed two weeks.

It is recommended to check the internal of the PS for sediments, residue, and scale on regular basis (the period depends on operating conditions) and clean it out from all the deposits.

3.2. If the operating conditions specified in sections 1.2.7 and 2.1 are not observed, this may lead to the flowmeter's fault, or the permissible limits of relative measurement error may be impaired.

External defects on the flowmeter's components or power cable can also lead to the flowmeter's fault or growth of the permissible limits of relative measurement error. Therefore, when the above-specified external defects are detected, contact the manufacturer's representative office for the information about the device's operability.

3.3. The presence of display indication means that power is applied to the flowmeter, the indicated information gives an idea of the flowmeter's performance. The list of possible faults indicated by the flowmeter is given in Part II of this manual.

Alarm (ER) situations are also indicated by status words. An ER situation is an event characterized by mismatch of measured values and flowmeter metrological characteristics, or by impossibility of measurements due to the violation of measurement conditions.

3.4. Regarding the design and operating conditions, the flowmeter refers to the devices that should be repaired by authorized dealers or by the manufacturer.

The error is localized on the site to an accuracy of a block: CS, SPS, PEA blocks or connection cable; faulty components are replaced by operable ones. If one PEA is faulty, both PEA pairs are replaced.

CAUTION! After replacement of the CS, PEAs or connection cables with PEAs, it is necessary to determine the values of dT_0 and P_{add} parameters for the corresponding measuring channel, and enter the values into the flowmeter. The procedure for determining dT_0 and P_{add} is described in Part II of this manual.

3.5. When the flowmeter is sent for warranty repair, the Passport shall be enclosed. Please specify post details, phone/fax numbers along with the way and address for redispaching.

When the device is dispatched for verification or repair complete with the PS, measuring parts and emitting surfaces of cut-in PEAs should be cleaned off sediments, residue, scale, etc.

4. PACKING, STORAGE AND TRANSPORTATION

4.1. "AFLOWT UF" flowmeter is packed into a separate container (corrugated carton or wooden box) along with the operational documentation.

Pipeline sections and fittings are delivered as a separate box.

4.2. The flowmeter should be kept in the manufacturer's box in a dry heated storeroom. The storeroom should be free from current-conductive dust, acid or alkali fumes and aggressive gases that may damage insulation.

During storage the flowmeter does not require any special maintenance.

4.3. The flowmeters can be transported by road, rail, sea or air provided that the following requirements are met:

- Flowmeter is transported packed in the manufacturer's box
- Protection against moisture is provided
- Temperature is within the range of - 30 to + 50 °C
- Humidity does not exceed 98 % at + 35 °C
- Vibration is within the range of 10-500 Hz with maximum 0.35 mm amplitude or 49 m/s²
- Impact acceleration does not exceed 98 m/s²
- Flowmeters are fixed to prevent damages.

APPENDIX A. View of components

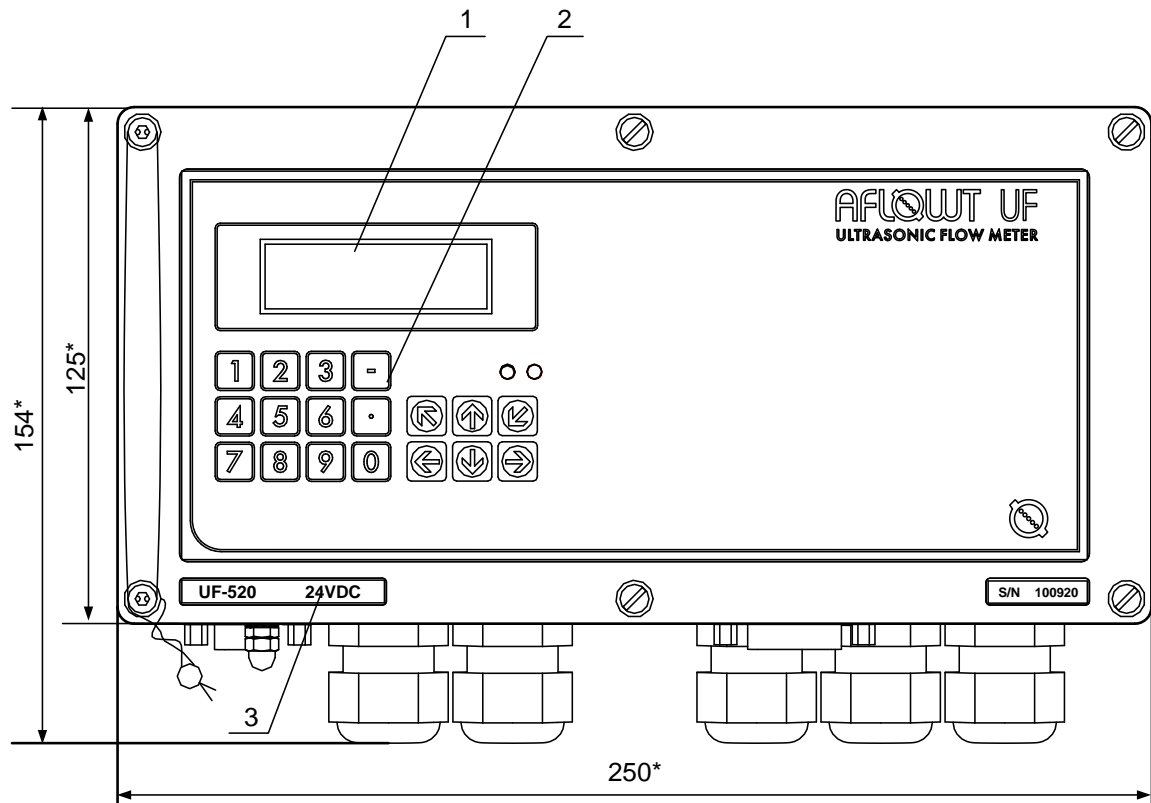

a) front view

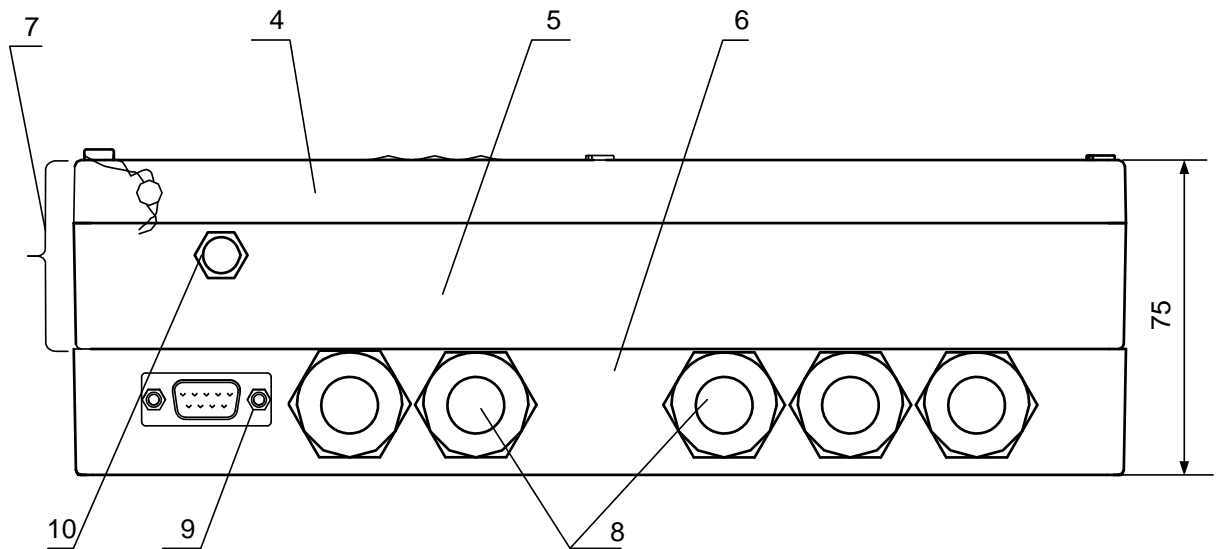

b) bottom view

* - reference dimension

1 – indicator; 2 – keyboard; 3 – power supply indication; 4 – Data Processing module; 5 – SPS module; 6 – Mount module; 7 – Data Processing Subblock; 8 – cable glands; 9 – RS-232 connector; 10 – grounding terminal.

Fig.A.1. Secondary Converter

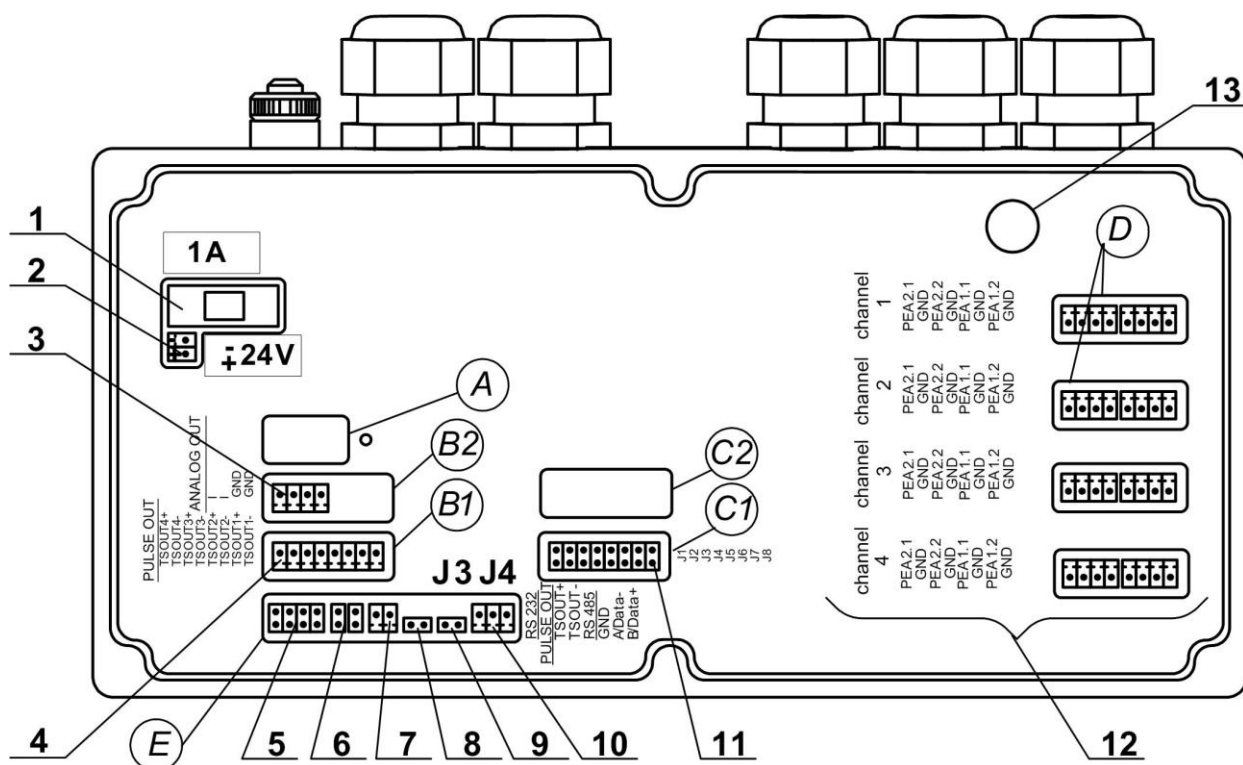
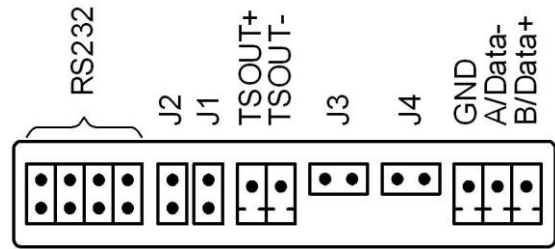

Fig.A.2. Data Processing subblock of the CS; bottom view

- A – reserve window;
- B1, C1 – windows for connectors of the Service module mounted into Slot 1;
- B2, C2 – windows for connectors of the Service module mounted into Slot 2;
- E – window for connectors of the "RS-232 / RS-485 / Universal output 0" Combined Module;
- D – window for connectors of the transmitting/receiving modules;
- 1 – Fuse terminal block (1 A, DC 24V);
- 2 – DC 24 V power supply connector;
- 3 – Analog output connector, output 2, Service module;
- 4 – Universal outputs connector, outputs 1-4, Service module;
- 5 – RS-232 Interface connector, Combined module;
- 6 – J2, J1 terminals used to set operation modes for Universal output 0, Combined module;
- 7 – "Universal output 0" connector, Combined module;
- 8, 9 – J3, J4 terminals used to set flowmeter's operation modes on the Combined module;
- 10 – RS-485 Interface connector, Combined module;
- 11 – terminals used to set operation modules for Universal outputs 1-4, Service module;
- 12 – connectors of the Transmitting/Receiving modules for connection of communication cables with PEAs;
- 13 – hole with a cap used to connect quartz frequency measuring cable (service connector used for flowmeter's verification).

Identification of connectors
on the RS-232 / RS-485/Universal output 0
Combined module, E window



NOTES: The cable from an external RS-232 connector is connected to the RS-232 connector located on the Mount module (see Fig. A.1).

Connectors located on the Communication Subblock of the Service modules are marked according to Table A.1.

Table A.1.

Output	Number of the slot where the module is installed	Output signals		Terminals	
		How the window is marked in Fig.A.2	Signals	How the window is marked in Fig.A.2	Terminals
Universal 1	1	B1	TSOUT1 +/-	C1	J1, J2
Universal 2			TSOUT2 +/-		J3, J4
Universal 3			TSOUT3 +/-		J5, J6
Universal 4			TSOUT4 +/-		J7, J8
Universal 5	2	B2	TSOUT1 +/-	C2	J1, J2
Universal 6			TSOUT2 +/-		J3, J4
Universal 7			TSOUT3 +/-		J5, J6
Universal 8			TSOUT4 +/-		J7, J8
Current 1	1	B1	I / GND	C1	-
Current 2	2	B2	I / GND	C2	-

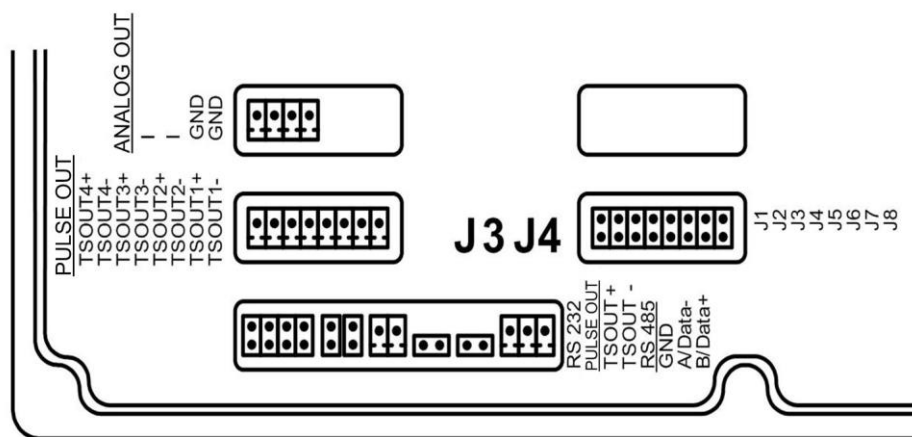

Fig.A.3. Example of marking the elements on the Communication Subblock of the Combined module and two Universal output modules

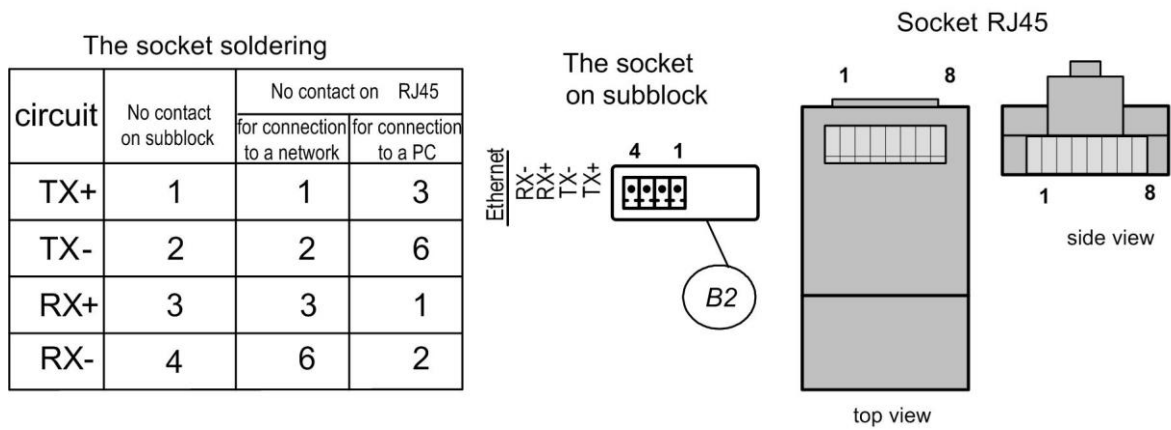
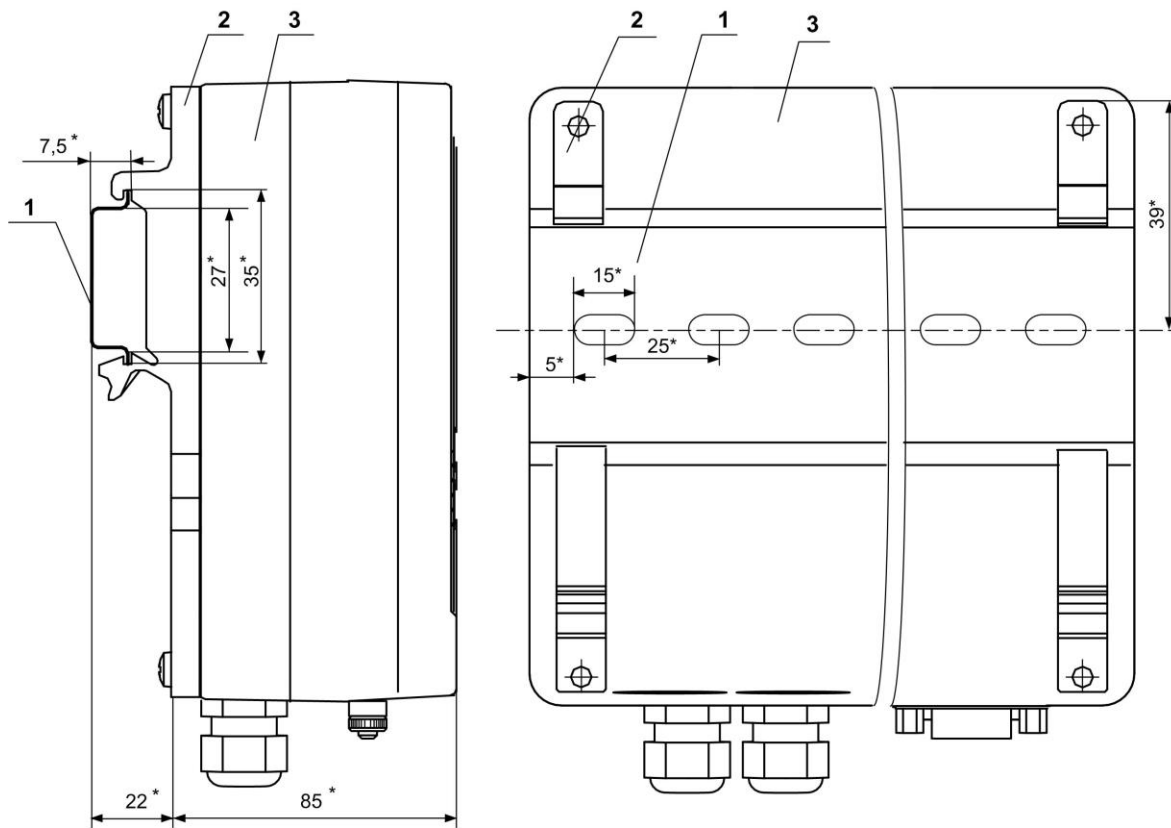

Fig.A.4. Ethernet connector in B2 window.



* - reference dimension

1 – DIN- rail; 2 – bracket; 3 – Mount module.

Fig.A.5. Mounting the CS on DIN-rail

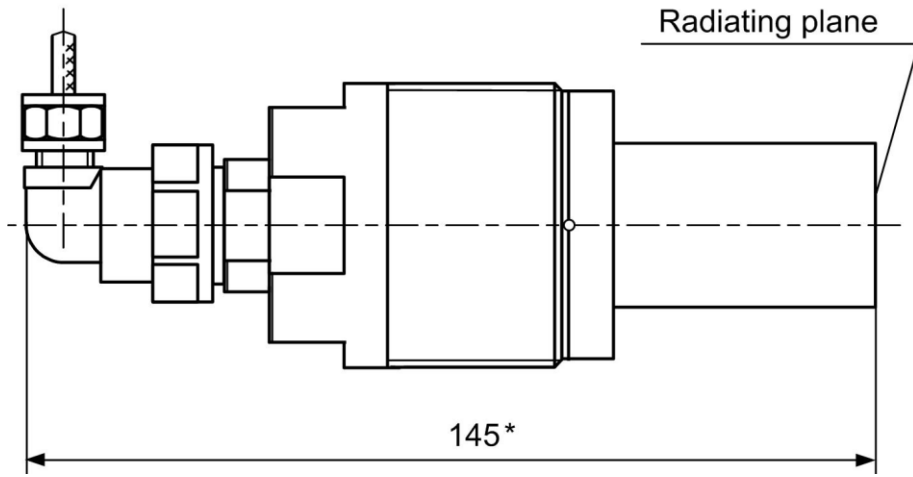

a) with plastic protection

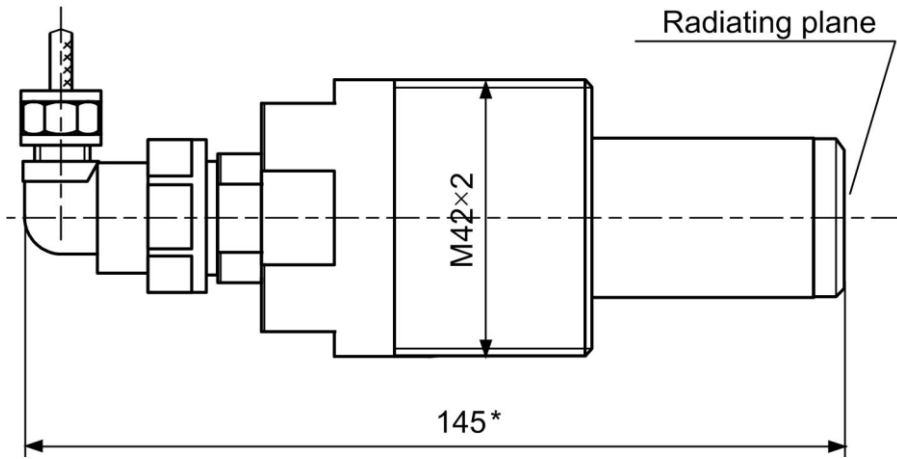

b) with titanium protection

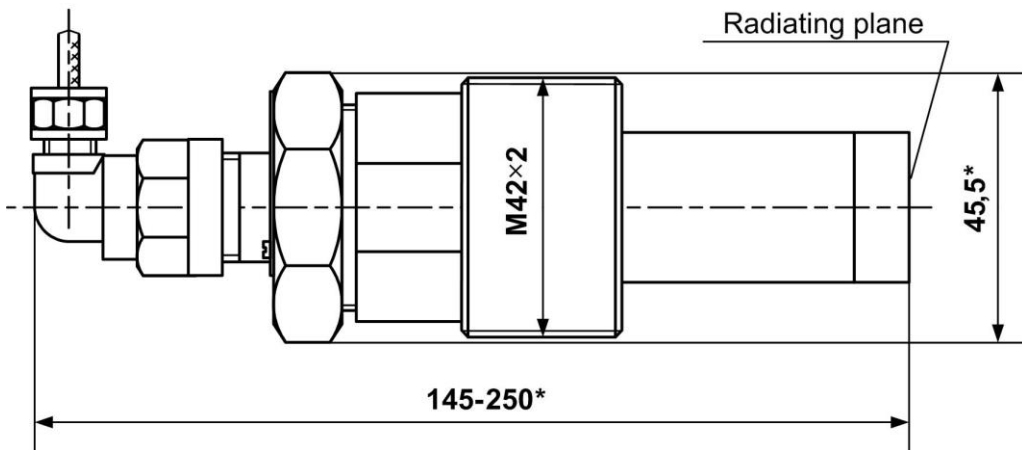

c) with titanium protection and cap nut

Weight is no more than 1 kg

* - reference dimension

Fig.A.6. Cut-in (screwable) PEA

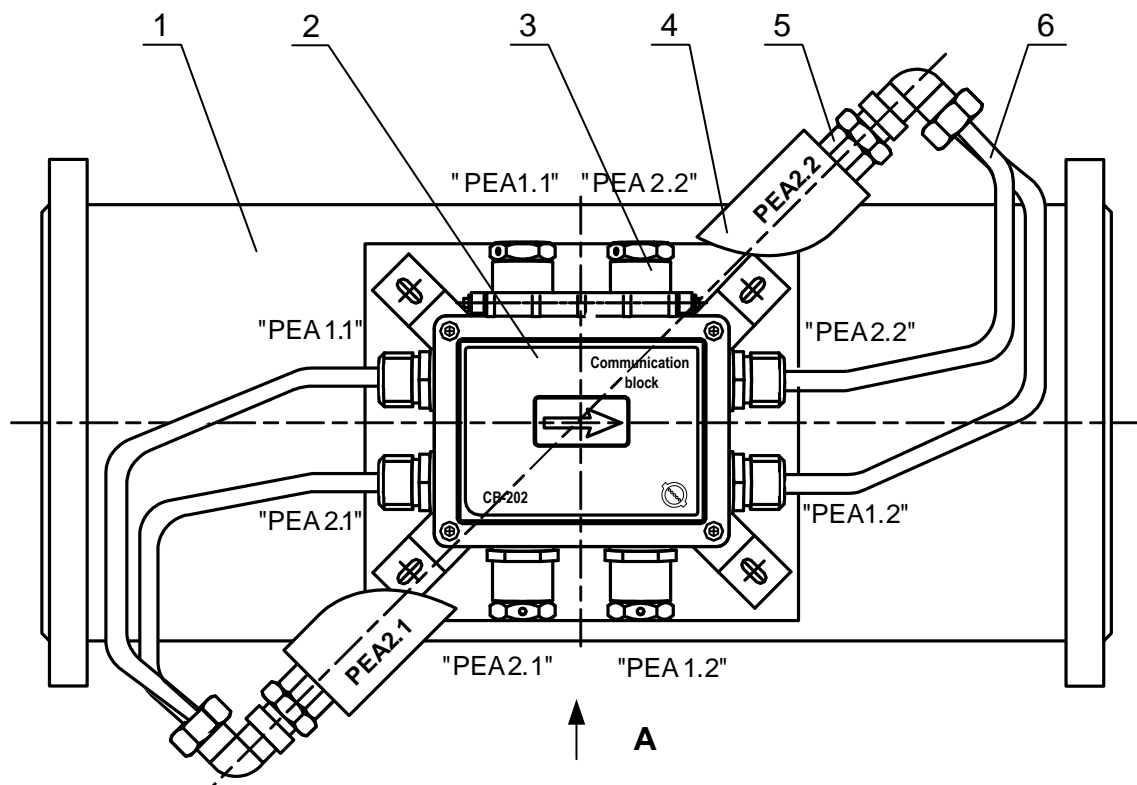

View A

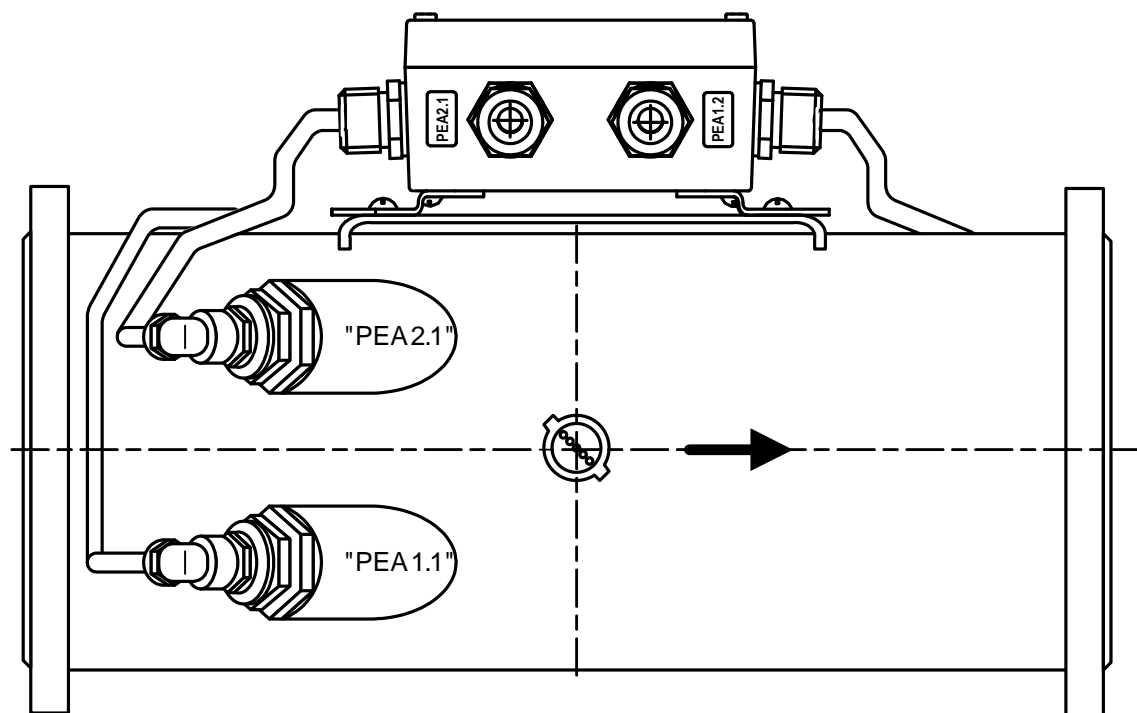

1 – pipeline section; 2 – communication block; 3 – CS connection cable through; 4 – pipe mount adaptor for mounting cut-in PEAs; 5 – cut-in PEA; 6 – PEA output in a copper sleeve

Fig.A.7. CP installed on PS-042 pipeline section with Communication block (two-beam sounding method, PEAs positioned on chords).

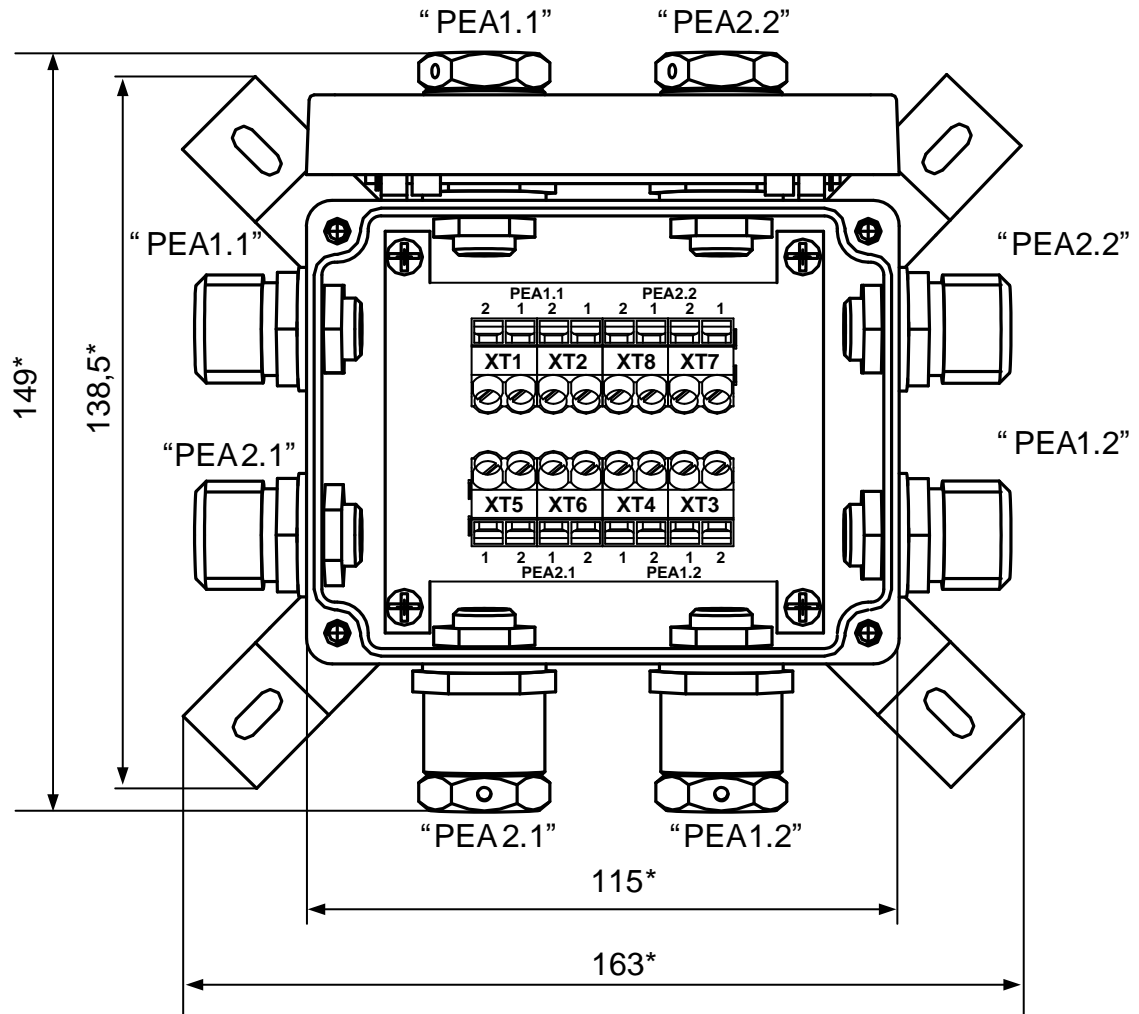

* - reference dimension

Fig.A.8. Communication block (two-channel version) for PS-042 pipeline section (view with cover removed)

APPENDIX B. Wiring diagrams

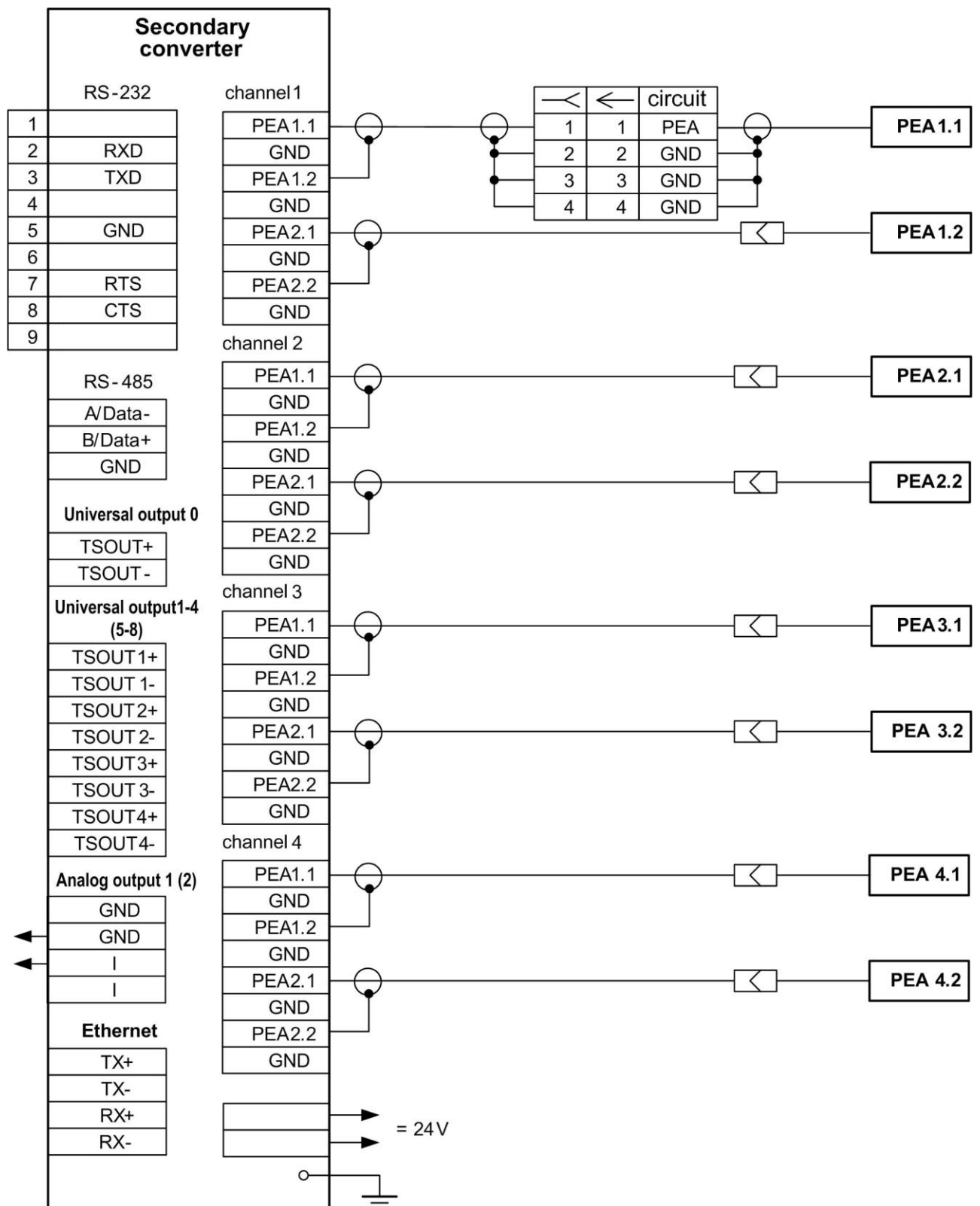

Fig.B.1. UF-54X d flowmeter wiring diagram

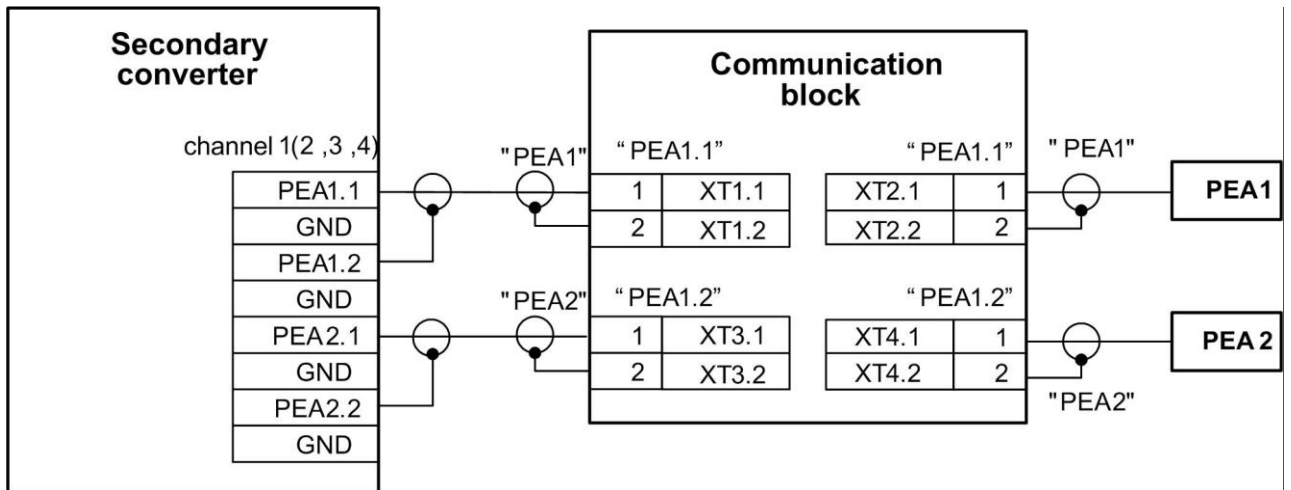

Fig.B.2. PEA connection diagram with use of Communication block, asymmetrical connection method

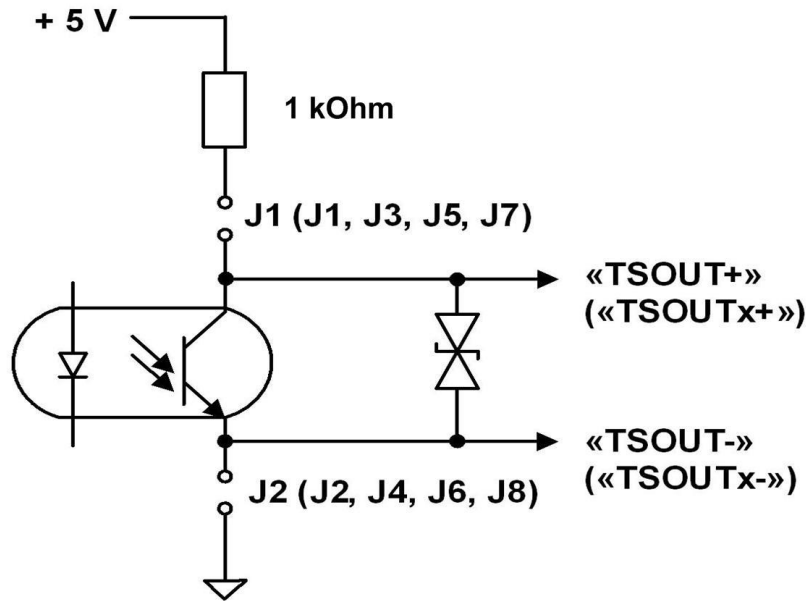

Fig.B.3. Universal outputs, circuit diagram of output stages

To match output stages to inputs of different types, the output stages are designed to work with either the internal galvanically isolated power source (active mode) or an external power source (passive mode). In standard supply configuration the output stages are in the passive mode.

Identifiers for the universal outputs are given in brackets.

In the active mode and in case that **Active level parameter** is set to **<high>**, output voltage in the logic mode and pulse amplitude in the pulse mode is within 2.4 to 5.0 V. In case of no pulse or at logic **<low>** the output voltage is less than 0.4 V. External load resistance shall be 1 kOhm as a minimum.

In the passive mode, power from an external power source with output DC voltage from 5 to 15 V can be applied. Permissible value of external load current is no more than 10 mA.

Connection of the output stage to the internal power source +5 V is made by placing jumpers between the corresponding terminals.

For the universal outputs, length of signal cables should be up to 300 m.